

G 3/8, G 1/2 - 5/2, 3/2 Pilot Operated High Flow Valves

- Streamlined construction.
- Compact dynamic seal design results in higher flow passages.
- Available in side port design in G 3/8, G 1/2 sizes.
- Option of gang manifolding upto 6 nos. of valves.

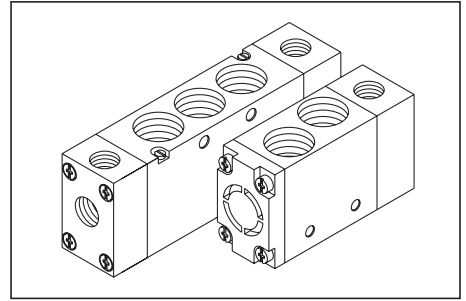

PART LIST - 5/2 WAY VALVES

NO.	DESCRIPTION	QTY.	
		Single Pilot	Double Pilot
1	Valve body	1	1
2	Spool	1	1
3	Air spring housing	1	-
4	Pilot housing	1	-
5	Piston	6	6
6	Spool seal	1	-
7	Gasket	1	2
8	Piston seal	1	2
9	O Ring (Pilot Hsg.)	1	2
10	Spring	1	2

Seal kit consists of items (2+6), 7, 8 & 9

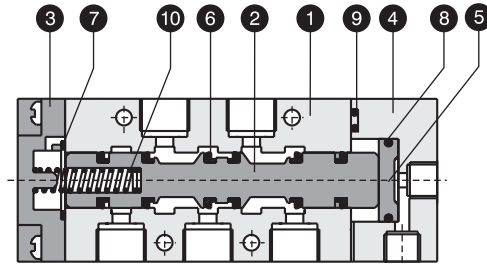

5/2 Single Pilot High Flow Valve

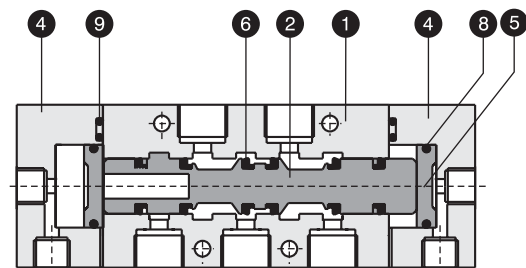

5/2 Double Pilot High Flow Valve

PART LIST - 3/2 WAY VALVES

NO.	DESCRIPTION	QTY.	
		Single Pilot	Double Pilot
1	Valve body	1	1
2	Spool	1	1
3	Air spring housing	1	-
4	Pilot housing	1	-
5	Piston	6	6
6	Spool seal	1	-
7	Gasket	1	2
8	Piston seal	1	2
9	'O' ring (Pilot hsg.)	1	2
10	Spring	1	2

Seal kit consists of items (2+6), 7, 8 & 9

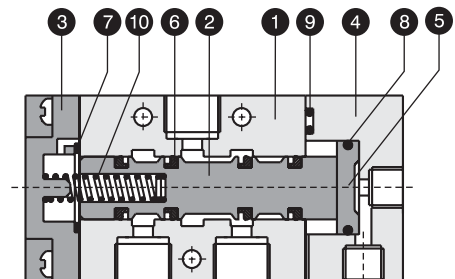

3/2 Single Pilot High Flow Valve

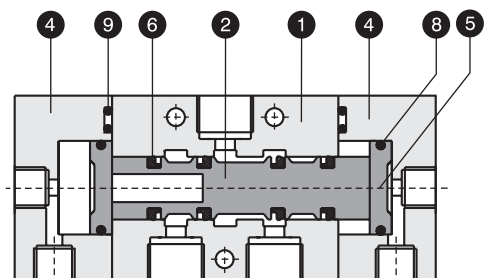

3/2 Double Pilot High Flow Valve

PORT CONFIGURATION FOR 5/2 VALVE

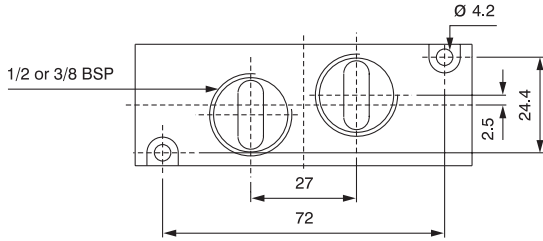

SINGLE PILOT HIGH FLOW VALVE

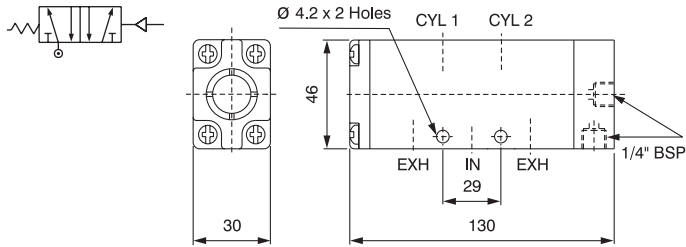

3/8", 1/2" 5/2 Single Pilot High Flow Valve

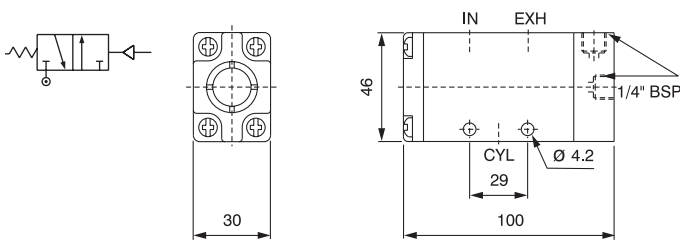

3/8", 1/2" 3/2 Single Pilot High Flow Valve

DOUBLE PILOT HIGH FLOW VALVE

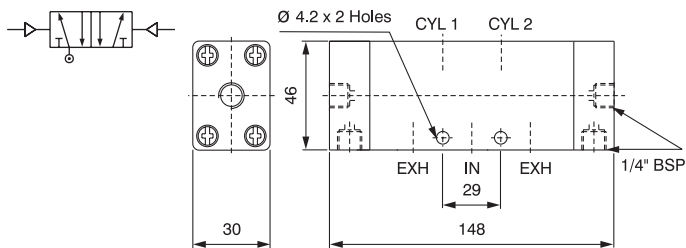

3/8", 1/2" 5/2 Double Pilot High Flow

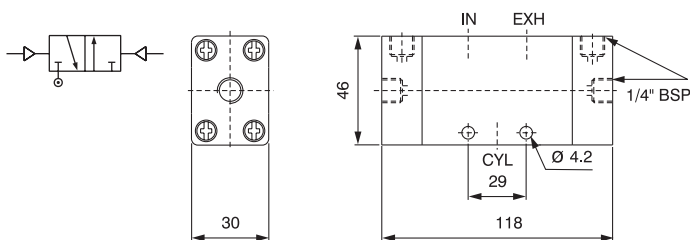

3/8", 1/2" 3/2 Double Pilot High Flow

PART NOS.

Type	Valve	Seal kit
G 3/8, 5/2 Single pilot valve	83004 PS	SK 93004 PS
G 1/2, 5/2 Single pilot valve	93004 PS	SK 93004 PS

Type	Valve	Seal kit
G 3/8, 3/2 Single pilot valve	83003 PS	SK 93003 PS
G 1/2, 3/2 Single pilot valve	93003 PS	SK 93003 PS

SPECIFICATIONS

Medium	Compressed air, Filtered
Design	Spool type with air spring return
Working pressure	1.5 - 10 kg. / sq.cm.
Ambient / fluid temp.	- 10 to 55° C
Cv (Nominal flow)	2.2 (2200 lit. / min.)
Response time at 5 bar	On Time : 10 m.s. Off Time : 30 m.s.
Materials	Body & Spool : Aluminium Seals : NBR

PART NOS.

Type	Valve	Seal kit
G 3/8, 5/2 Double pilot valve	83004 PP	SK 93004 PP
G 1/2, 5/2 Double pilot valve	93004 PP	SK 93004 PP

Type	Valve	Seal kit
G 3/8, 3/2 Double pilot valve	83003 PP	SK 93003 PP
G 1/2, 3/2 Double pilot valve	93003 PP	SK 93003 PP

SPECIFICATIONS

Medium	Compressed air, Filtered
Design	Spool type with air spring return
Working pressure	1.5 - 10 kg. / sq.cm.
Ambient / fluid temp.	- 10 to 55° C
Cv (Nominal flow)	2.2 (2200 lit. / min.)
Response time at 5 bar	On Time : 20 m.s.
Materials	Body & Spool : Aluminium Seals : NBR