

G 1/4 - G 1 5/2 Pilot Operated Poppet Valves

- Robust poppet design allows high flow rates combined with long life expectancy of seals.
- The design of face sealing on poppet makes valve 'self-cleaning' and is ideal under adverse air conditions.
- Offered in 3/8" basic and 3/4" basic versions.
- Facility of gang manifolding having common inlet and exhaust with individual outlets.

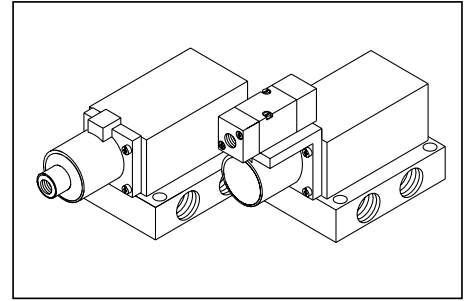

PART LIST

NO.	DESCRIPTION	QTY.	
		Single Pilot	Double Pilot
1	Valve body	1	1
2	Pilot housing	1	1
3	Poppet and piston assly.	1	1
4	'U' cup packing	1	1
5	Spool	1	1
6	Gasket for pilot housing	1	1
7	'O' ring (Sub-base plate)	5	5
8	'O' ring (Pilot housing)	1	1
9	Inlet seals	2	2
10	'O' ring (Retainer)	3	3
11	Outlet seals	2	2
12	Spring	1	1
13	'O' ring (Pilot valve)	--	2
14	Pilot housing (Exel valve)	--	2
15	Piston	--	2
16	Piston seal	--	2
17	Body (Pilot valve)	--	1
18	Spool (Pilot valve)	--	1
19	Dancing seals	--	4

Seal kit consists of items 4, 6, 7, 8, 9, 10 & 11 for single pilot valve.

Seal kit consists of items 4, 6, 7, 8, 9, 10, 11, 13, 16 & (17 + 19) for double pilot valve.

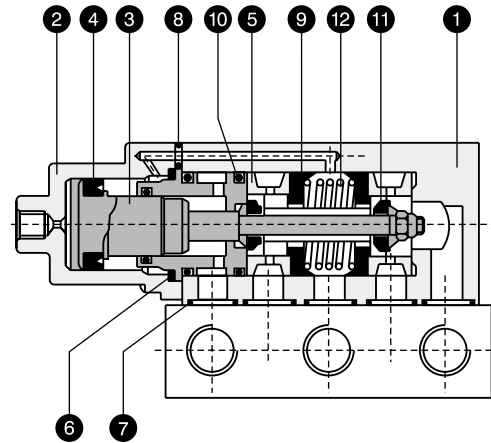

5/2 Single Pilot Poppet Valve

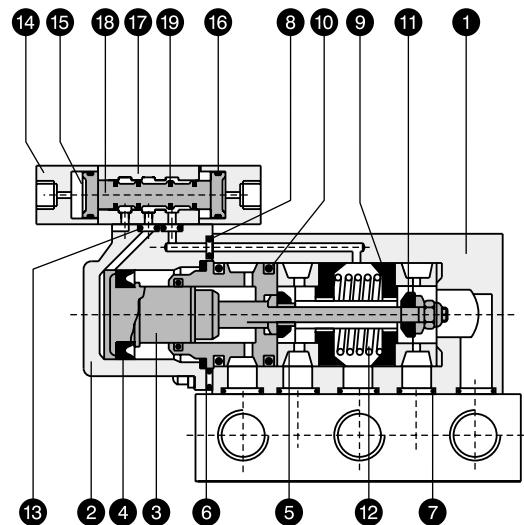

5/2 Double Pilot Poppet Valve

5/2 SINGLE PILOT POPPET VALVE

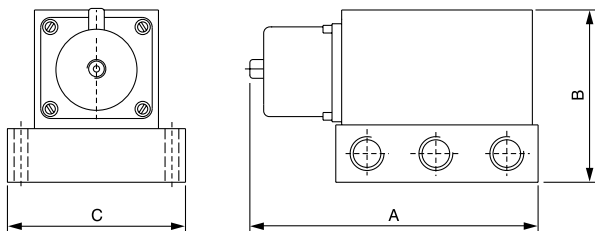
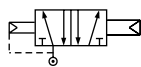

SIZE	A	B	C
G 1/4	156	76	76
G 3/8	156	76	76
G 1/2	156	81	76
G 1/2	220	100	95
G 3/4	220	105	95
G 1	230	115	102

PART NOS.

	Type	Valve with base plate	Valve without base plate	Base Plate	Seal kit
3/8" Basic	1/4" Single pilot	3455 PM	2455 PM	PBS 3814	SK 3456 P
	3/8" Single pilot	3456 PM	2456 PM	PBS 3838	
	1/2" Single pilot	3461 PM	2461 PM	PBS 3812	
3/4" Basic	1/2" Single pilot	3457 PM	2457 PM	PBS 3412	SK 3458 P
	3/4" Single pilot	3458 PM	2458 PM	PBS 3434	
	1" Single pilot	3459 PM	2459 PM	PBS 3810	

SPECIFICATIONS

Medium	Compressed air, Filtered					
Design	Poppet type design					
Working pressure	1.5 - 10 Kg./sq. cm.					
Ambient / fluid temp.	- 10° to 85° C					
Pilot port connection	G 1/8					
Cv (Nominal flow)	3/8" Basic			3/4" Basic		
	1/4"	3/8"	1/2"	1/2"	3/4"	1"
	1.9	2.04	2.38	5.4	5.8	5.8
Response time at 5 Bar	On time : 30 ms. Off time : 45 ms.					
Materials	Body, Base, Pilot Housing : Aluminium Seals : NBR					

5/2 DOUBLE PILOT POPPET VALVE

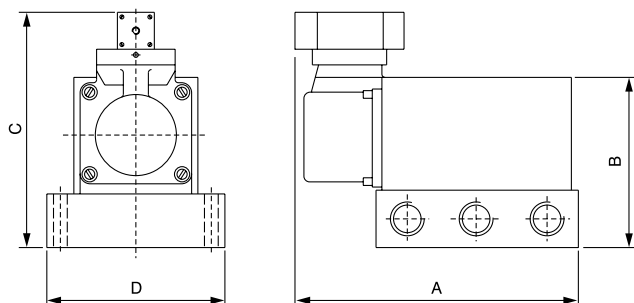
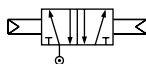

SIZE	A	B	C	D
G 1/4	156	76	125	76
G 3/8	156	76	125	76
G 1/2	156	81	130	76
G 1/2	220	100	160	95
G 3/4	220	105	165	95
G 1	230	115	175	102

PART NOS.

	Type	Valve with base plate	Valve without base plate	Base Plate	Seal kit
3/8" Basic	1/4" Double pilot	825 PM	725 PM	PBS 3814	SK 826 P
	3/8" Double pilot	826 PM	726 PM	PBS 3838	
	1/2" Double pilot	830 PM	730 PM	PBS 3812	
3/4" Basic	1/2" Double pilot	827 PM	727 PM	PBS 3412	SK 828 P
	3/4" Double pilot	828 PM	728 PM	PBS 3434	
	1" Double pilot	829 PM	729 PM	PBS 3810	

SPECIFICATIONS

Medium	Compressed air, Filtered					
Design	Poppet type design					
Working pressure	1.5 - 10 Kg./sq. cm.					
Ambient / fluid temp.	- 10° to 85° C					
Pilot port connection	G 1/8					
Cv (Nominal flow)	3/8" Basic			3/4" Basic		
	1/4"	3/8"	1/2"	1/2"	3/4"	1"
	1.9	2.04	2.38	5.4	5.8	5.8
Response time at 5 bar	On time : 30 ms.					
Materials	Body, Base, Pilot Housing : Aluminium Seals : NBR					