

G 1/4 - G1 5/2 Manually Operated Poppet Valves

- Offered in 3/8" basic and 3/4" basic versions.
- Available in Hand lever actuation and Foot lever actuation.
- Robust poppet design allows high flow rates combined with long life expectancy of seals.
- The design of face sealing on poppet makes valve 'self - cleaning' and is ideal under adverse air conditions.

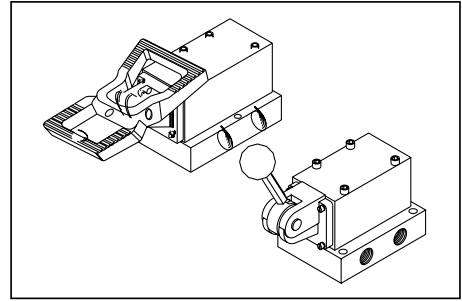

PART LIST

NO.	DESCRIPTION	QTY.	
		Hand Lever Optd.	Foot Lever Optd.
1	Valve Body	1	1
2	Poppet and piston assly.	1	1
3	Spool	2	2
4	'O' ring for sub base plate	5	5
5	Inlet seals	2	2
6	'O' ring for retainer	1	1
7	Outlet seals	2	2
8	Spring (Body)	1	1
9	Hand lever assembly	1	-
10	Disc	1	1
11	Detent	1	1
12	Roller	1	1
13	Bracket	1	1
14	Detent spring	1	1
15	Retainer	1	1
16	Foot pedal	-	1

Seal Kit consists of items 4,5,6 & 7

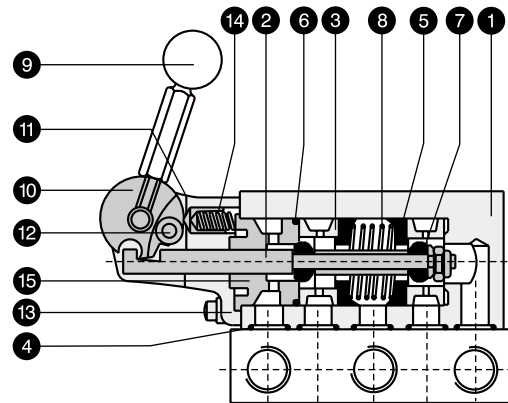

Hand Lever Operated Poppet Valve

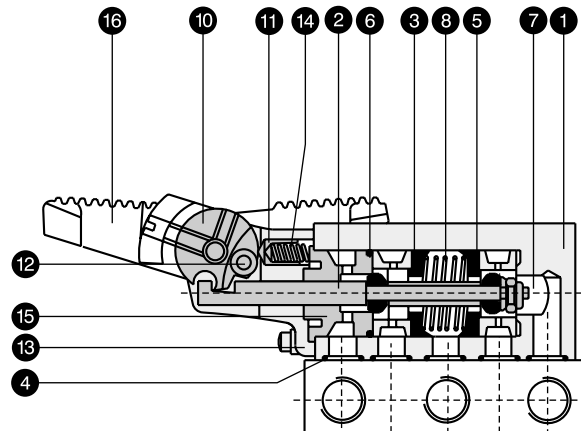

Foot Lever Operated Poppet Valve

G 1/4 - G 1, 5/2 HAND LEVER OPERATED POPPET VALVE

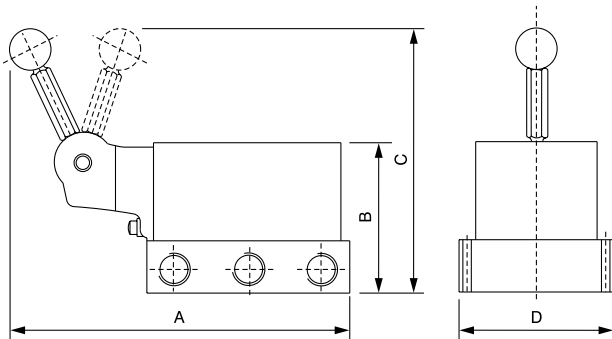
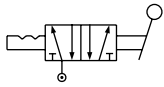

	SIZE	A	B	C	D
3/8" Basic	G 1/4	185	76	150	76
	G 3/8	185	76	150	76
	G 1/2	185	81	150	76
3/4" Basic	G 1/2	220	100	210	95
	G 3/4	220	105	215	95
	G 1	225	115	225	102

PART NOS.

	Valve Size	Valve with base plate	Valve without base plate	Base Plate	Seal kit
3/8" Basic	1/4" Hand Lever	3320 MH	2320 MH	PBS 3814	SK 3321 M
	3/8" Hand Lever	3321 MH	2321 MH	PBS 3838	
	1/2" Hand Lever	3326 MH	2326 MH	PBS 3812	
3/4" Basic	1/2" Hand Lever	3322 MH	2322 MH	PBS 3412	SK 3323 M
	3/4" Hand Lever	3323 MH	2323 MH	PBS 3434	
	1" Hand Lever	3324 MH	2324 MH	PBS 3410	

SPECIFICATIONS

Medium	Compressed air, Filtered					
Design	Poppet type					
Working pressure	0 - 10 Kg./sq. cm.					
Ambient / fluid temp.	- 10° to 55° C					
Cv (Nominal flow)	3/8" Basic			3/4" Basic		
	1/4"	3/8"	1/2"	1/2"	3/4"	1"
	1.9	2.04	2.38	5.4	5.8	5.8
Materials	Body, Base: Aluminium Seals : NBR					

G 1/4 - G 1, 5/2 - FOOT LEVER OPERATED POPPET VALVE

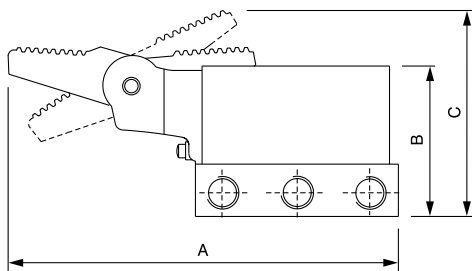
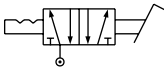

	SIZE	A	B	C	WIDTH
3/8" Basic	G 1/4	190	76	125	76
	G 3/8	190	76	125	76
	G 1/2	190	81	130	76
3/4" Basic	G 1/2	275	100	161	95
	G 3/4	275	105	165	95
	G 1	280	115	175	102

PART NOS.

	Valve Size	Valve with base plate	Valve without base plate	Base Plate	Seal kit
3/8" Basic	1/4" Foot Lever	3320 MFL	2320 MFL	PBS 3814	SK 3321 M
	3/8" Foot Lever	3321 MFL	2321 MFL	PBS 3838	
	1/2" Foot Lever	3326 MFL	2326 MFL	PBS 3812	
3/4" Basic	1/2" Foot Lever	3322 MFL	2322 MFL	PBS 3412	SK 3323 M
	3/4" Foot Lever	3323 MFL	2323 MFL	PBS 3434	
	1" Foot Lever	3324 MFL	2324 MFL	PBS 3410	

SPECIFICATIONS

Medium	Compressed air, Filtered					
Design	Poppet type					
Working pressure	0 - 10 Kg./sq. cm.					
Ambient / fluid temp.	- 10° to 55° C					
Cv (Nominal flow)	3/8" Basic			3/4" Basic		
	1/4"	3/8"	1/2"	1/2"	3/4"	1"
	1.9	2.04	2.38	5.4	5.8	5.8
Materials	Body, Base: Aluminium Seals : NBR					