

G 1/8 - G 3/4 Inline Flow Control Valves

- Ideal for streamlined piping layout.
- Allows free flow in one direction and controlled flow in the other so as to regulate the speed of the cylinder.
- Option of Knob type and Recess type design.
- Better control of air flow achieved by giving fine threads on regulating pin.

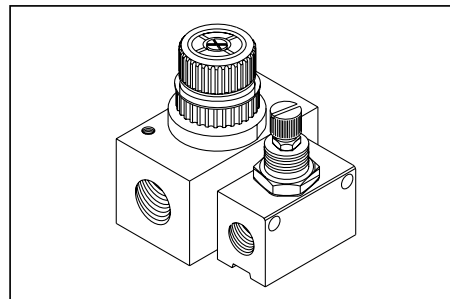

PART LIST

NO.	DESCRIPTION	QTY.	
		Knob Type	Recess Type
1	Valve body	1	1
2	Stem	1	1
3	Knob type pin	1	-
4	Recess type pin	-	1
5	'U' cup	1	1
6	'O' ring for pin	1	1
7	'O' ring for stem	1	1
8	Lock ring	1	1
9	Nut	1	--
10	Knob	1	--

Seal kit consists of items 5, 6 & 7.

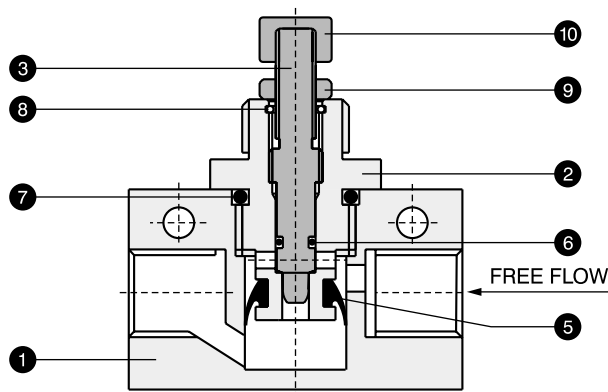

Knob type design

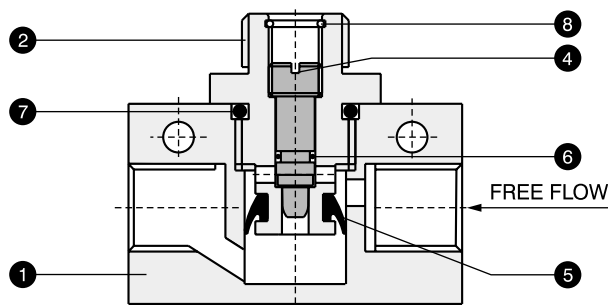

Recess type design

SPECIFICATIONS

Port connection		G 1/8	G 1/4	G 3/8	G 1/2	G 3/4
Part no.	Knob Type	IL 1899 K	IL 1499 K	IL 3899 K	IL 1201 K	IL 3401 K
	Recess Type	IL 1899 R	IL 1499 R	IL 3899 R	IL 1201 R	IL 3401 R
	Seal kit	SK 1899	SK 1499	SK 3899	SK 1201	
Medium	Compressed air, Filtered					
Design	Screw type flow control valve					
Pressure range	0.2 - 10 bar					
Temperature range	-10° to 85° C					
Material	a) Body : Aluminium b) Stem, Screw : Brass c) Seals : NBR d) External / Internal : Spring steel locking ring					
Nominal flow (Liters / min)	Controlled	0 to 125	0 to 350	0 to 600	0 to 1200	0 to 1200
	Free	190	465	920	1750	1780

G 1/8, G 1/4, G 3/8
INLINE FLOW CONTROL VALVE

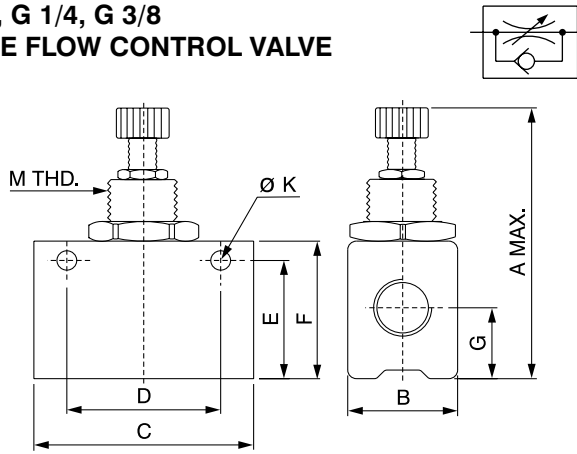

Knob type design

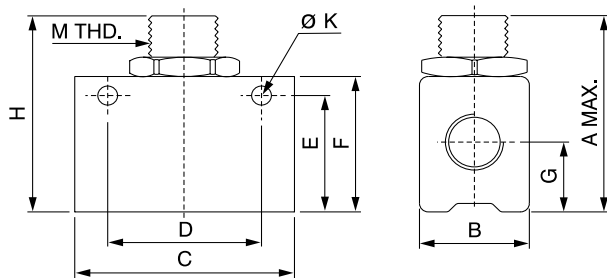

Recess type design

PORT BSP	A MAX		B	C	D	E	F	G	DIA K	M THDS
	Knob	Rec								
G 1/8	46	34	18	34	24	18.5	22	10	4.2	M 12 X 1
G 1/4	64	42	25	50	35	27	32	16	4.5	M 16 X 1.5
G 3/8	72	48	28	58	38	32	38	19	4.5	M 20 X 1.5

G 1/2, G 3/4
INLINE FLOW CONTROL VALVE

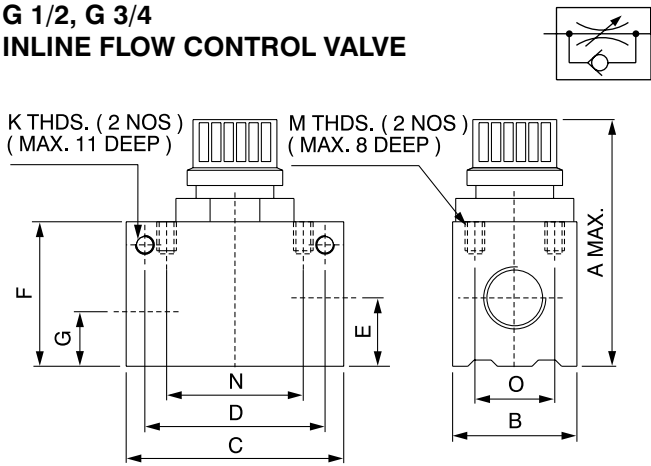

Knob type design

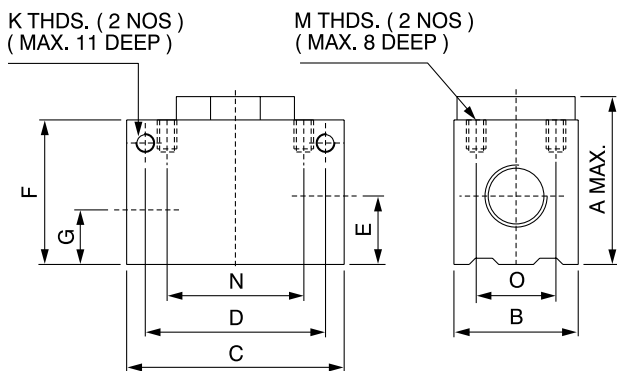

Recess type design

PORT BSP	A MAX		B	C	D	E	F	G	K THDS	M THDS	N	O
	Knob	Rec										
G 1/2	90	68	40	70	58	23	46.5	17	M 6	M 6 X 1 P	44	26
G 3/4	90	68	40	70	58	23	46.5	17	M 6	M 6 X 1 P	44	26

FLOW REGULATION CURVE

