

**FLU (C) NN**  
ROTARY UNIONS





# R-100 ROTARY UNIONS

**Features** :- Double ball bearings, Balanced face sealing lapped to optical flatness, Secondary sealing of Nitrile, Viton, PTFE, Available in MONO FLOW, DUO FLOW with FIXED SIPHON and ROTATING SIPHON.

**Material of Construction** :- Standard Union - 1/4" to 3/4" - Brass Housing & S.S. Rotor 1" & above - C. I. Housing & M. S. Motor.

for other material Combination Consult Engineering Dept.

**OPERATING DATA :**  
 Max Speed - 1500 RPM  
 Max. Temperature - 160°C  
 Max Pressure - 35 kg./cm<sup>2</sup>  
 Media Water

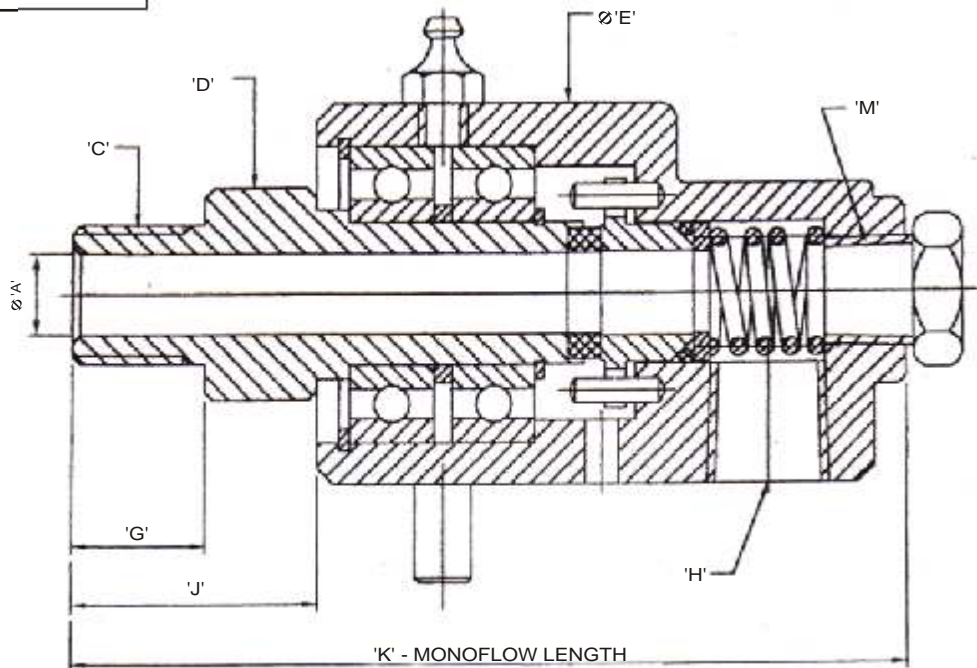

(A) FIG. 'A' - MONOFLOW UNION

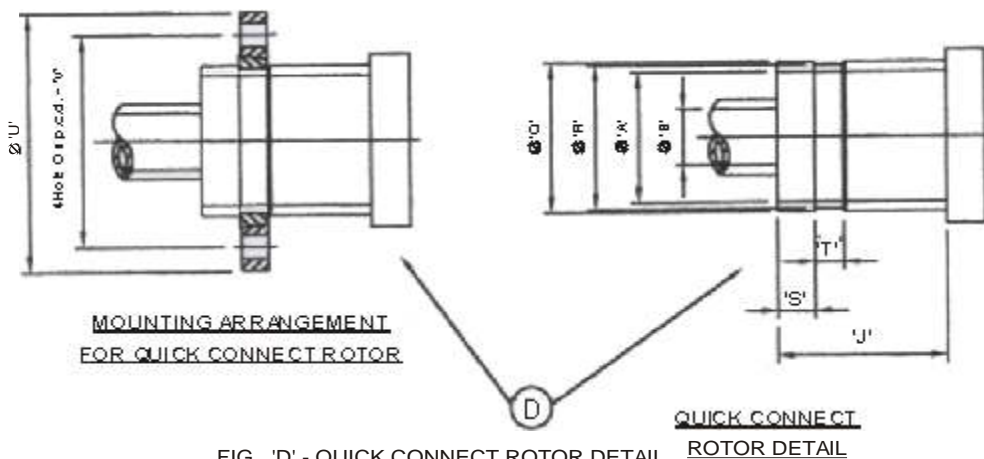
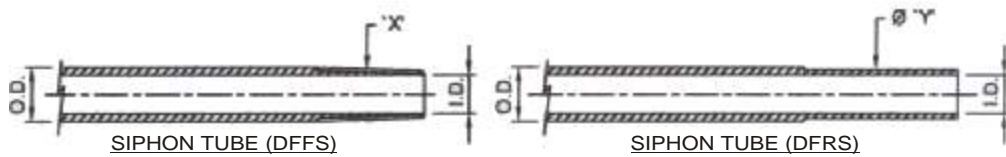
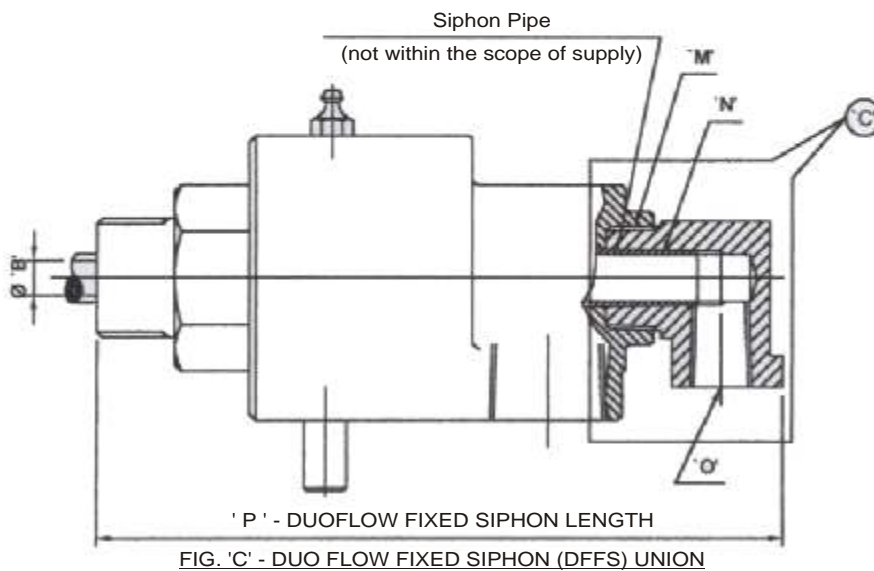
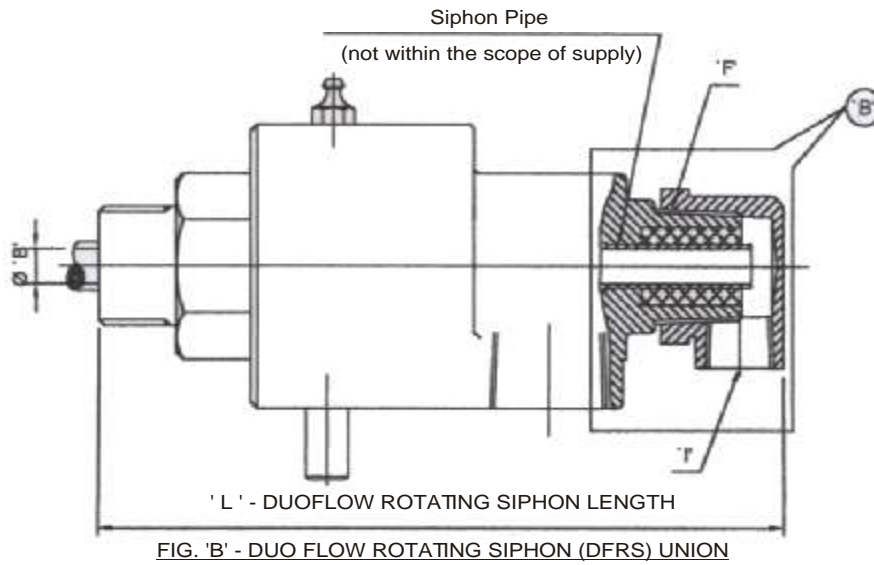

FIG. 'D' - QUICK CONNECT ROTOR DETAIL

QUICK CONNECT ROTOR DETAIL



# R-100 ROTARY UNIONS



SIPHON TUBE DIMENSION OF DFFS & DFRS ROTARY UNIONS

TUBE DIM.	3/8"	1/2"	3/4"	1"	1-1/4"	1-1/2"	2"	2-1/2"	3"	3-1/2"	4"
I.D.	3	6	6.35	10	15	20	25	32	40	50	50
O.D.	6	10	13.5	17.5	21.3	26.9	33.7	42.4	48.3	60.3	60.3
'X' BSPT	M6	1/8"	1/4"	3/8"	1/2"	3/4"	1"	1 1/4"	1 1/2"	2"	2"
'Y'	-	8.9	12.6	16.4	18.85	25.3	31.85	41.85	47.8	59.8	59.8

## R-100 ROTARY UNIONS

### ● Rotating Siphon Application

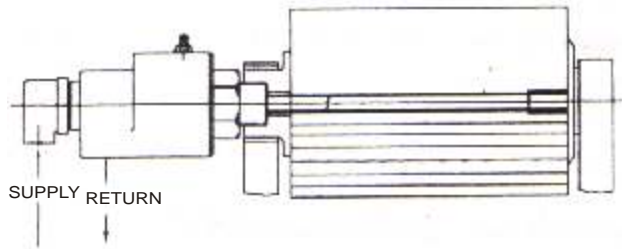

ROTARY UNION ARRANGED FOR ROTATING SIPHON DUO FLOW APPLICATION. The centre tube is fixed to the other end of journal & rotates along with journal media is fed through union end & return line is through the orifice since the siphon tube rotates along with rotor this type is called the ROTATING SIPHON DUO FLOW UNION.

### ● Fixed Siphon Application

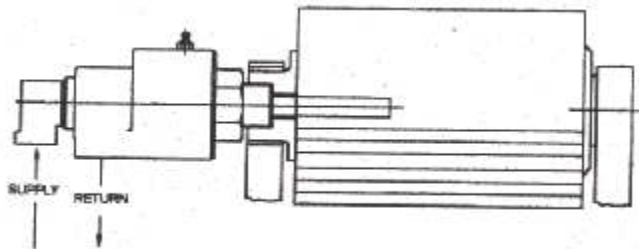

ROTARY UNION ARRANGED FOR FIXED SIPHON DUO FLOW APPLICATION. The centre tube is threaded on to elbow of union & media is fed through it. The return is through the orifice.

### ● Fixed Siphon Application

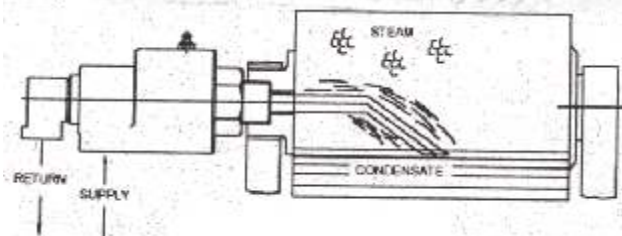

ROTARY UNION FIXED SIPHON DUO FLOW ARRANGED FOR STEAM SERVICE. Steam introduced through rotor & condensate collected through siphon tube.

### ● Mono Flow Application

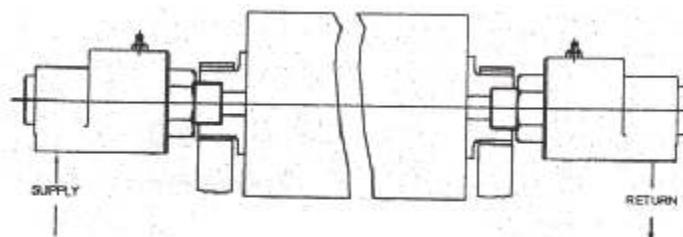

ROTARY UNIONS MONO FLOW ARRANGED FOR COOLING OR HEATING OF JOURNAL. Both end rotary unions are installed, one supply of media & other for return. SELECT L.H. ROTOR THREAD WHEN THE JOURNAL ROTATES IN CLOCKWISE DIRECTION WHEN VIEWED FROM THE UNION END. AND R.H. ROTOR THREAD WHEN IT ROTATES IN ANTI CLOCKWISE.

MODEL	Ø 'A' ROTOR HOLE	Ø 'B' SIPHON HOLE	'C' ROTOR THREAD BSP	'D' ACROSS FLAT	Ø 'E'	'F' BSP	'G'	'H' BSP	'I' BSP	'J'	'K'	'L'	'M' BSP	'N' BSP	'O' BSP	'P'	Ø 'Q'	Ø 'R'	'S'	'T'	Ø 'U'	'V'	WEIGHT M / F UNION
R 0100-002-001	6.4	-	1/4" RH	22	45	-	13	1/4"	-	26.5	98.5	-	-	-	-	-	-	-	-	-	-	-	0.6 Kg.
R 0100-002-002	6.4	-	1/4" LH	22	45	-	13	1/4"	-	26.5	98.5	-	-	-	-	-	-	-	-	-	-	-	0.6 Kg.
R 0100-003-003	9.5	-	3/8" RH	22	45	-	16	3/8"	-	29.5	100.5	-	1/4"	M6	1/4"	123	-	-	-	-	-	-	0.6 Kg.
R 0100-003-004	9.5	-	3/8" LH	22	45	-	16	3/8"	-	29.5	100.5	-	1/4"	M6	1/4"	123	-	-	-	-	-	-	0.6 Kg.
R 0100-004-005	12.7	3.175	1/2" RH	28	57	1/2"	19	1/2"	3/8"	35	124	159	3/8"	1/8"	3/8"	150	-	-	-	-	-	-	1.2 Kg.
R 0100-004-006	12.7	3.175	1/2" LH	28	57	1/2"	19	1/2"	3/8"	35	124	159	3/8"	1/8"	3/8"	150	-	-	-	-	-	-	1.2 Kg.
R 0100-005-007	19	6.35	3/4" RH	36	72	3/4"	22	3/4"	1/2"	38	142	180	1/2"	1/4"	3/8"	173.5	-	-	-	-	-	-	2.2 Kg.
R 0100-005-008	19	6.35	3/4" LH	36	72	3/4"	22	3/4"	1/2"	38	142	180	1/2"	1/4"	3/8"	173.5	-	-	-	-	-	-	2.2 Kg.
R 0100-005-079	19	6.35	Q.C.	-	72	3/4"	-	3/4"	1/2"	38	142	180	1/2"	1/4"	3/8"	173.5	30	28	8	13	75	55	2.2 Kg.
R 0100-006-009	25.4	9.525	1" RH	46	81	1"	22	1"	3/8"	43.2	165.2	220	3/4"	3/8"	1/2"	208	-	-	-	-	-	-	3.0 Kg.
R 0100-006-010	25.4	9.525	1" LH	46	81	1"	22	1"	3/8"	43.2	165.2	220	3/4"	3/8"	1/2"	208	-	-	-	-	-	-	3.0 Kg.
R 0100-006-080	25.4	9.525	Q.C.	-	81	1"	-	1"	3/8"	43.2	165.2	220	3/4"	3/8"	1/2"	208	35	31.8	8	13	80	60	3.0 Kg.
R 0100-007-011	32	12.7	1-1/4" RH	50	89	1-1/4"	27	1-1/4"	1/2"	54	186	240	1"	1/2"	1/2"	235	-	-	-	-	-	-	3.7 Kg.
R 0100-007-012	32	12.7	1-1/4" LH	50	89	1-1/4"	27	1-1/4"	1/2"	54	186	240	1"	1/2"	1/2"	235	-	-	-	-	-	-	3.7 Kg.
R 0100-007-081	32	12.7	Q.C.	-	89	1-1/4"	-	1-1/4"	1/2"	54	186	240	1"	1/2"	1/2"	235	41.02	38.1	12.7	12.5	100	75	3.7 Kg.
R 0100-008-013	37	19	1-1/2" RH	54	108	1-1/2"	29	1-1/2"	3/4"	59	221	276	1-1/4"	3/4"	3/4"	271	-	-	-	-	-	-	5.9 Kg.
R 0100-008-014	37	19	1-1/2" LH	54	108	1-1/2"	29	1-1/2"	3/4"	59	221	276	1-1/4"	3/4"	3/4"	271	-	-	-	-	-	-	5.9 Kg.
R 0100-008-082	37	19	Q.C.	-	108	1-1/2"	-	1-1/2"	3/4"	59	221	276	1-1/4"	3/4"	3/4"	271	50	45	12.7	15.5	105	80	5.9 Kg.
R 0100-009-015	46	19	2" RH	65	117	2"	29	2"	1"	64.5	238	304	1-1/2"	3/4"	3/4"	298	-	-	-	-	-	-	8.2 Kg.
R 0100-009-016	46	19	2" LH	65	117	2"	29	2"	1"	64.5	238	304	1-1/2"	3/4"	3/4"	298	-	-	-	-	-	-	8.2 Kg.
R 0100-009-083	46	19	Q.C.	-	117	2"	-	2"	1"	64.5	238	304	1-1/2"	3/4"	3/4"	298	59	56	17	15.5	130	100	8.2 Kg.
R 0100-010-017	63	31.75	2-1/2" RH	80	150	2-1/2"	40	2-1/2"	1"	89.5	309	409	2"	1"	1"	382	-	-	-	-	-	-	-
R 0100-010-018	63	31.75	2-1/2" LH	80	150	2-1/2"	40	2-1/2"	1"	89.5	309	409	2"	1"	1"	382	-	-	-	-	-	-	-
R 0100-010-084	63	31.75	Q.C.	-	150	2-1/2"	-	2-1/2"	1"	89.5	309	409	2"	1"	1"	382	80	75	20	16	150	120	-
R 0100-011-019	75	31.75	3" RH	-	165	2-1/2"	45	2-1/2"	1-1/4"	97	350	425	2"	1"	1-1/2"	438	-	-	-	-	-	-	-
R 0100-011-020	75	31.75	3" LH	-	165	2-1/2"	45	2-1/2"	1-1/4"	97	350	425	2"	1"	1-1/2"	438	-	-	-	-	-	-	-
R 0100-011-085	75	31.75	Q.C.	-	165	2-1/2"	-	2-1/2"	1-1/4"	97	350	425	2"	1"	1-1/2"	438	92.08	88.11	28.57	18.2	180	145	-
R 0100-012-108	88	38.1	3-1/2" RH	-	181	3-1/2"	45	2-1/2"	1-1/2"	97	298	424	2-1/2"	1-1/4"	1-1/4"	377	-	-	-	-	-	-	-
R 0100-012-109	88	38.1	3-1/2" LH	-	181	3-1/2"	45	2-1/2"	1-1/2"	97	298	424	2-1/2"	1-1/4"	1-1/4"	377	-	-	-	-	-	-	-
R 0100-012-086	88	38.1	Q.C.	-	181	3-1/2"	-	2-1/2"	1-1/2"	96	285	424	2-1/2"	1-1/4"	1-1/4"	377	101.6	97.63	28.57	20.3	195	160	-
R 0100-013-110	95	50.8	4" RH	-	210	4"	44	3"	2"	87.35	396	565	3"	2"	1-1/2"	510	-	-	-	-	-	-	-
R 0100-013-111	95	50.8	4" LH	-	210	4"	44	3"	2"	87.35	396	565	3"	2"	1-1/2"	510	-	-	-	-	-	-	-
R 0100-013-087	95	50.8	Q.C.	-	210	4"	-	3"	2"	87.35	396	565	3"	2"	1-1/2"	510	113	109	28.57	21	195	160	-

# R-100 ROTARY UNIONS

## Recommended Hose Installation

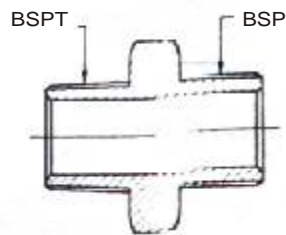
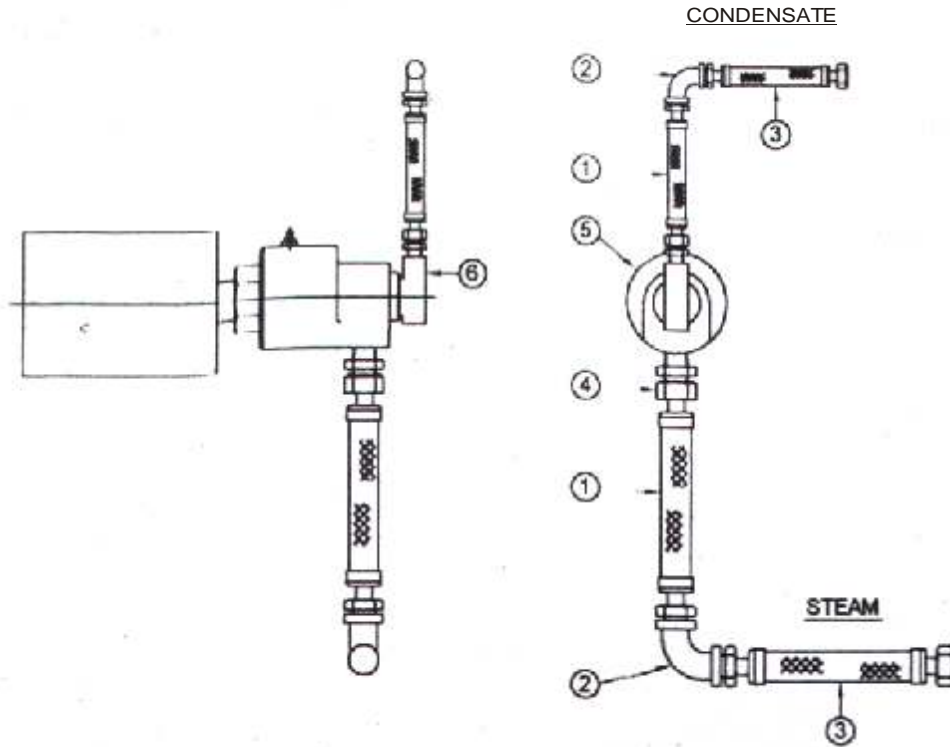

THREADED STUD COUPLING  
FOR HOSES WITH UNION END

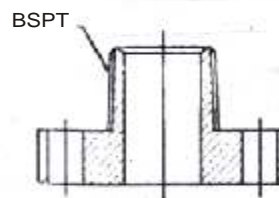

FLANGED NIPPLE FOR HOSES  
WITH FLANGED END CONNECTIONS

1 & 3) Stainless Steel Corrugated & Wire braided Hose.

2) C.I. / M.S. Elbow or bend

4) Hose end connection (Union or Flanged)

5) Rotary Union

6) Duo Flow Elbow